



For decades MAUCOUR equipped professional boats with these types of systems which have proven reliable and requires low maintenance.

These mountings are used when there is a need for intermediate bearing.

The design and implementation of all this elements are made in our factory, enabling us to monitor the production and ongoing monitoring of quality.

All these sterngears could be approved by various classification societies.

This system includes an external water lubricated bearing complete assembly with an integral rope guard, a bronze spacer tube and in the front part bearing/gland assembly, The length of the tube is defined by the measurement 'S' given by the customer.

Depending on the application, a water inlet, usually connected to the engine cooling system can be set up on the tube close to the seal.

## WOOD HULL

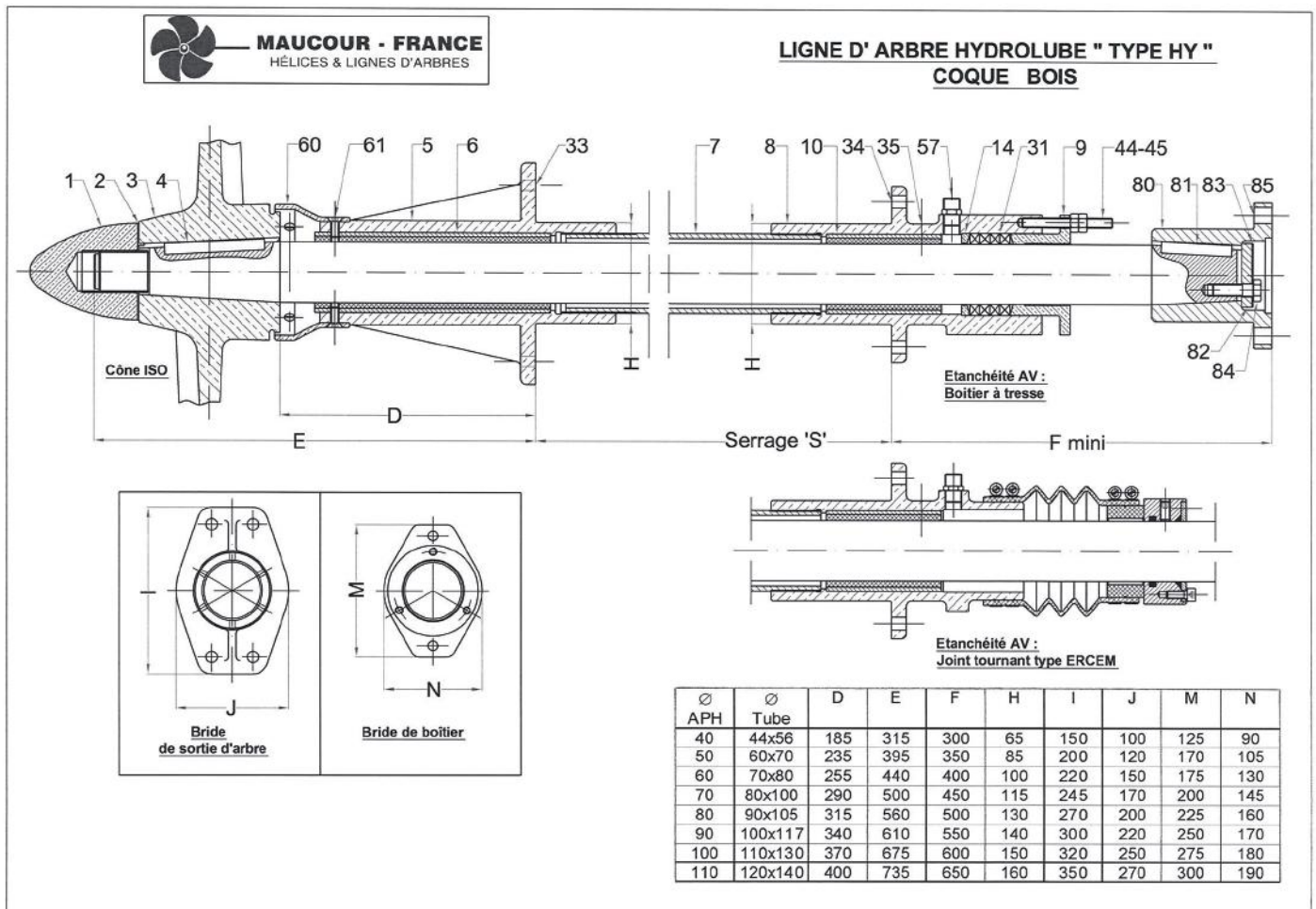

Ce document n'est pas contractuel - This document is not contractual

Veuillez nous consulter pour de plus amples informations techniques lors d'un projet.