

SUR TABLEAU ARRIÈRE 0° / 12°

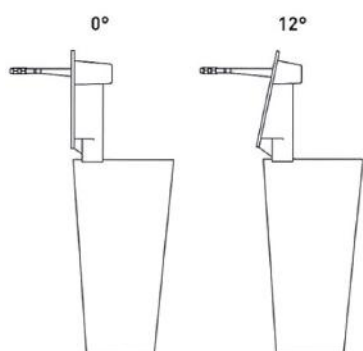

Type	Ø mèche en mm	Surface en dm ²	Poids en Kg	Matière	Référence
14 / 10 S0-S12	40	10.5	15	Cupro Manganèse	SAFBUBSE1410(S0)/(S12)
16 / 7 S0-S12	40	7.17	12	Cupro Aluminium	SAFBUCSE1607(S0)/(S12)
16 / 11 S0-S12	40	11.09	18	Cupro Aluminium	SAFBUCSE1611(S0)/(S12)
16 / 13 S0-S12	40	13.10	19.5	Cupro Aluminium	SAFBUCSE1613(S0)/(S12)
17 / 15 S0-S12	40	15	27	Inox 316 L	SAFBUISE1715(S0)/(S12)
43 / 20 S0-S12	60	20.03	52	Inox 316 L	SAFBUISE4320(S0)/(S12)
38 / 40 S0	80	41.53	160	Inox 316 L	SAFBUISE3840S0
38 / 50	80	50.68	170	Inox 316 L	SAFBUISE3850S0

 Autres dimensions sur demande

À TUBE JAUMIÈRE

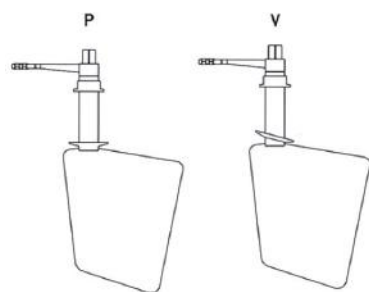

Type	Ø mèche en mm	Surface en dm ²	Poids en Kg	Matière	Référence
12 / 6 P-V	30	5.77	10	Cupro Manganèse	SAFAUBSE1206(P)/(V)
16 / 7 P-V	40	7.17	12	Cupro Aluminium	SAFAUCSE1607(P)/(V)
14 / 10 P-V	40	10.5	14	Cupro Manganèse	SAFAUBSE1410(P)/(V)
16 / 11 P-V	40	10.77	15.5	Cupro Aluminium	SAFAUCSE1611(P)/(V)
16 / 13 P-V	40	12.8	17	Cupro Aluminium	SAFAUCSE1613(P)/(V)
25 / 11 P-V	40	10.69	16.5	Cupro Aluminium	SAFAUCSE2511(P)/(V)
17 / 15 P-V	40	15	23	Inox 316 L	SAFAUISE1715(P)/(V)
45 / 16 P-V	60	16.26	48	Cupro Aluminium	SAFAUCSE4516(P)/(V)
45 / 19 P-V	60	18.21	51	Cupro Aluminium	SAFAUCSE4519(P)/(V)
45 / 20 P-V	60	19.73	54	Cupro Aluminium	SAFAUCSE4520(P)/(V)
78 / 24 P-V	60	24.20	62	Inox 316 L	SAFAUISE7824(P)/(V)
36 / 30 P-V	70	30	110	Inox 316 L	SAFAUISE3630(P)/(V)
38 / 35 P-V	80	34.90	150	Inox 316 L	SAFAUISE3835(P)/(V)
42 / 70 P	80	69.90	230	Inox 316 L	SAFAUISE4270P
56 / 13 P	60	13.50	40	Cupro Aluminium	SAFAUCSE5613P
50 / 18 P	70	18.10	60	Cupro Aluminium	SAFAUCSE5018P

Cavitation Plate en supplément

 Autres dimensions sur demande