



NOZZLES



Main advantage of the nozzle is that it increases the thrust of the propeller. A propeller in nozzle provides approximately 25% of total thrust more than a propeller without a nozzle.

WHY?

- Give more thrust
- Give more pulling power
- Less fuel consumption
- Give more speed, from the same power input
- Less fuel consumption
- Reduced vibrations
- Safety in ice

APPLICATION

- Tugs and pusher tugs
- Fishing vessels
- Research vessels
- Supply vessels and special ships
- Dredger and cable – laying vessels...

WE OFFER:

- 2D Design · 3D simulation
- Production according customer requests
- Quality tests
- Register classification BV · DNV · LR · GL · RMRS · ABS · Ice Class
- Differents types: 19A, 37, HTE, EPR, High Speed...
- Up to 6 meters diameter

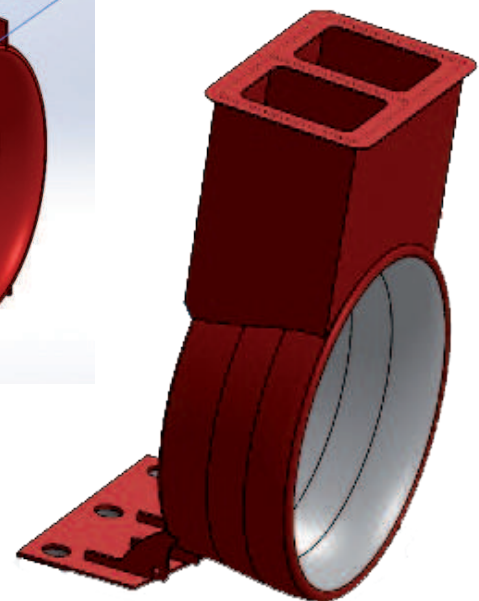
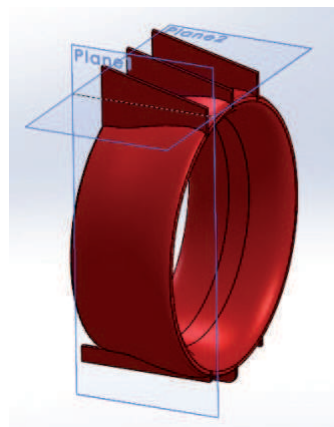

- MORE THRUST
- MORE TRACTION
- LESS FUEL CONSUMPTION
- MORE SPEED AT THE SAME POWER
- LESS VIBRATIONS
- SAFETY IN ICE