



## ERCEM GV



### Operating principles:

ERCEM seal is a mechanical seal which operate thanks to the friction of the

rotating stainless steel ring and static carbon ring. The nitrile bellows fixed to the stern tube with collars 316L provides compression between the steel ring and the carbon ring . The rotating seal ERCEM tolerate misalignment and

provides a perfect axial sealing thanks to the two O-rings mounted in the stainless steel ring and radial by pressing the carbon and stainless steel ring . Our ERCEM sealing are mounted on propeller shaft but also on rudders .

- Direct evolution of the ERCEM : The ERCEM GV. This system is particularly suitable for fast boats (above 20 knots ) when sterntube empties himself by depression due to speed. It can be use too for boat without water or air inlet on sterntube, improving considerably the lubrication of water lubricate bearing, with reduction of electrolytic reactions caused by the water stagnation in sterntube.

## CARBON/GRAPHITE RING

Rings are produced with Isomolded, very fine grain, high strength, high density, isotropic graphite resin impregnated for high mechanical and sealing applications.

This material may tolerate temperatures up to 200 ° Celsius. Rings are produced on CNC machines to ensure a glossy surface state on the contact face.

Depending on the application, the carbon ring may be provided with polyamide fitting to provide better lubrication in water or air vent. We use a non-metallic material to avoid electrolytic phenomena.



## STAINLESS STEEL RING

316L stainless steel rings are machined on CNC machine to ensure a perfect surface condition and exacting tolerances. The rings are slipped onto the shaft and held in place by 3 setscrews cup end in stainless steel 316L.

The rings are also equipped with two O-rings in nitrile to ensure a perfect seal.

Concerning stainless steel rings for shaft above Ø55mm, they are composed of two parties to facilitate mounting.





## BELLOW

ERCEM can be fitted with two different types of bellows :

Reinforced bellows are made of high strength reinforced nitrile covered by Aramid more known as Kevlar®. It can be mounted on our entire range. Its advantages are increased resistance to petrochemicals products, UV, cuts, strains and also to high temperatures.

Our range of bellows is tested under high pressure in our workshops to return to our quality criteria.



## WATER PICK UP KITS

Water Pick-Up Kits include everything needed to connect your ERCEM to a point in the engine's raw water cooling system: Brass Tees, hose and 316L clamps.

Reference	Référence
Water pick up kits- Tee 3/4"	<b>ERCKIT1</b>
Water pick up kits-- Tee 1"	<b>ERCKIT2</b>
Water pick up kits-- Tee 1"1/4	<b>ERCKIT3</b>
Water pick up kits-- Tee 1"1/2	<b>ERCKIT4</b>

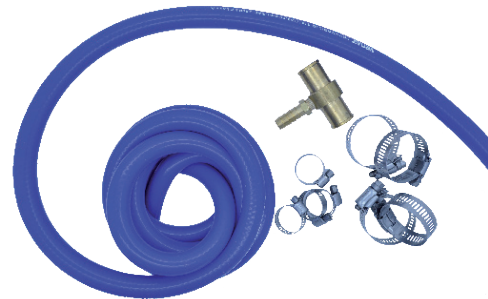

## ERCEM SEALS IN FEW WORDS

- The ERCEM is a 100% French origin
- With an experience of several decades, it is known for its reliability.
- Ecological: no lubrication using petrochemical material.
- Economic:
  - \* No maintenance required
  - \* No greasing
  - \* No lip seals replacement
  - \* No braid packing to tighten the stuffy box
  - \* No shaft wear due to friction of lip seals or braid
- Tolerates misalignment and offers perfect axial sealing

They trust us:

ALLAIS - ALLURES YACHTING - ALUTECH - CATANA - COUACH - CNB - CHANTIER NAVAL DELAVERGNE - DINTRA BV - H2X - OCEA - MICHIGAN WHEEL MARINE EUROPE - NSI - SIBIRIL - STX FRANCE - TRANSMETAL INDUSTRIE - UFAST - UFIN ...



**ERCEM GV SEAL**

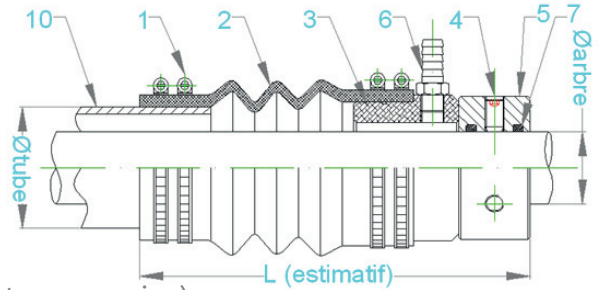

Description:

L = total length (the dimension 'L' is given as "indicative" without compression)

C= compression

+ or - 2 mm (simple)

+ or - 4 mm (reinforced)

- (1) Stainless steel clamps (2) Reinforced bellow (3) Graphite ring (4) Stainless steel screw (5) Stainless steel ring  
(6) Water inlet (7) O'rings

SHAFT Ø	TUBE Ø	Reinforced Bellow	L	C
25	41/46	<b>ERCCO16002502</b>	169	14
25	53/62	<b>ERCCO16002504</b>	186	10
25	64/70	<b>ERCCO16002505</b>	186	10
25.4 (1")	41/46	<b>ERCCO16025402</b>	169	14
25.4 (1")	53/62	<b>ERCCO16025404</b>	186	10
25.4 (1")	64/70	<b>ERCCO16025405</b>	186	10
28	41/46	<b>ERCCO16002802</b>	174	14
28	53/62	<b>ERCCO16002804</b>	191	10
28	64/70	<b>ERCCO16002805</b>	191	10
28.6(1.1/8")	41/46	<b>ERCCO160028602</b>	174	14
28.6(1.1/8")	53/62	<b>ERCCO160028604</b>	191	10
28.6(1.1/8")	64/70	<b>ERCCO160028605</b>	191	10
30	41/46	<b>ERCCO16003002</b>	174	14
30	53/62	<b>ERCCO16003004</b>	191	10
30	64/70	<b>ERCCO16003005</b>	191	10
31.75(1.1/4")	41/46	<b>ERCCO160031702</b>	174	14
31.75(1.1/4")	53/62	<b>ERCCO160031704</b>	191	10
31.75(1.1/4")	64/70	<b>ERCCO160031705</b>	191	10
34	53/62	<b>ERCCO16003402</b>	191	10
34	64/70	<b>ERCCO16003404</b>	179	10
34	75/84	<b>ERCCO16003405</b>	189	14
35	53/62	<b>ERCCO16003502</b>	191	10
35	64/70	<b>ERCCO16003504</b>	179	10
35	75/84	<b>ERCCO16003505</b>	189	14
38.1(1.1/2")	53/62	<b>ERCCO160038102</b>	191	10
38.1(1.1/2")	64/70	<b>ERCCO160038104</b>	179	10
38.1(1.1/2")	75/84	<b>ERCCO160038105</b>	189	14
40	53/62	<b>ERCCO16004002</b>	199	10
40	64/70	<b>ERCCO16004004</b>	187	10
40	75/84	<b>ERCCO16004005</b>	197	14
41.2 (1.5/8")	53/62	<b>ERCCO160041202</b>	199	10

SHAFT Ø	TUBE Ø	Reinforced Bellow	L	C
41.2 (1.5/8")	64/70	<b>ERCCO160041204</b>	187	10
41.2 (1.5/8")	75/84	<b>ERCCO160041205</b>	197	14
44,45(1.3/4")	64/70	<b>ERCCO160044401</b>	189	10
44,45(1.3/4")	75/84	<b>ERCCO160044402</b>	199	14
45	64/70	<b>ERCCO16004501</b>	189	10
45	75/84	<b>ERCCO16004502</b>	199	14
47.6(1.7/8")	64/70	<b>ERCCO160047601</b>	189	10
47.6(1.7/8")	75/84	<b>ERCCO160047602</b>	199	14
50	75/84	<b>ERCCO16005001</b>	199	14
50	88/93	<b>ERCCO16005002</b>	217	14
50	94/100	<b>ERCCO16005003</b>	217	14
50.8 (2 ")	75/84	<b>ERCCO160050801</b>	199	14
50.8 (2 ")	88/93	<b>ERCCO160050802</b>	217	14
50.8 (2 ")	94/100	<b>ERCCO160050803</b>	217	14
55	75/84	<b>ERCCO16005501</b>	207	14
55	88/93	<b>ERCCO16005502</b>	225	14
55	94/100	<b>ERCCO16005503</b>	225	14
55	104/114	<b>ERCCO16005504</b>	280	25
57.15(2.1/4")	75/84	<b>ERCCO160057101</b>	207	14
57.15(2.1/4")	88/93	<b>ERCCO160057102</b>	225	14
57.15(2.1/4")	94/100	<b>ERCCO160057103</b>	225	14
57.15(2.1/4")	104/114	<b>ERCCO160057104</b>	280	25
60	88/93	<b>ERCCO16006001</b>	225	14
60	94/100	<b>ERCCO16006002</b>	225	14
60	104/114	<b>ERCCO16006003</b>	280	25
63.5(2.1/2")	88/93	<b>ERCCO160063501</b>	225	14
63.5(2.1/2")	94/100	<b>ERCCO160063502</b>	225	14
63.5(2.1/2")	104/114	<b>ERCCO160063503</b>	280	25
65	88/93	<b>ERCCO16006501</b>	225	14
65	94/100	<b>ERCCO16006502</b>	225	14
65	104/114	<b>ERCCO16006503</b>	280	25



## ERCEM GV SEAL SPARE PARTS



ERCEM GV REFERENCE	BELLOWS	CARBON RING	STAINLESS STEEL RING
ERCCO16002502	ERCSO15100003	ERCBC15500003	ERCBI15302501
ERCCO16002504	ERCSO15100005	ERCBC15500004	ERCBI15302501
ERCCO16002505	ERCSO15100005	ERCBC15500004A	ERCBI15302501
ERCCO06025402	ERCSO15100003	ERCBC15500003	ERCBI153025401
ERCCO16025404	ERCSO15100005	ERCBC15500004	ERCBI153025401
ERCCO16025405	ERCSO15100005	ERCBC15500004A	ERCBI153025401
ERCCO16002802	ERCSO15100003	ERCBC15500005	ERCBI15302801
ERCCO16002804	ERCSO15100005	ERCBC15500006	ERCBI15302801
ERCCO16002805	ERCSO15100005	ERCBC15500005	ERCBI15302801
ERCCO160028602	ERCSO15100003	ERCBC15500005	ERCBI153028601
ERCCO160028604	ERCSO15100005	ERCBC15500006	ERCBI153028601
ERCCO160028605	ERCSO15100005	ERCBC15500005	ERCBI153028601
ERCCO16003002	ERCSO15100003	ERCBC15500005	ERCBI15303001
ERCCO16003004	ERCSO15100005	ERCBC15500006	ERCBI15303001
ERCCO16003005	ERCSO15100005	ERCBC15500005	ERCBI15303001
ERCCO160031702	ERCSO15100003	ERCBC15500005A	ERCBI153031701
ERCCO160031704	ERCSO15100005	ERCBC15500006A	ERCBI153031701
ERCCO160031705	ERCSO15100005	ERCBC15500005A	ERCBI153031701
ERCCO16003402	ERCSO15100005	ERCBC15500007	ERCBI15303401
ERCCO16003404	ERCSO15100006	ERCBC15500008	ERCBI15303401
ERCCO16003405	ERCSO15100007	ERCBC15500008	ERCBI15303401
ERCCO16003502	ERCSO15100005	ERCBC15500007	ERCBI15303501
ERCCO16003504	ERCSO15100006	ERCBC15500008	ERCBI15303501
ERCCO16003505	ERCSO15100007	ERCBC15500008	ERCBI15303501
ERCCO160038102	ERCSO15100005	ERCBC15500007A	ERCBI153038101
ERCCO160038104	ERCSO15100006	ERCBC15500008A	ERCBI153038101
ERCCO160038105	ERCSO15100007	ERCBC15500008A	ERCBI153038101
ERCCO16004002	ERCSO15100005	ERCBC15500009	ERCBI15304001
ERCCO16004004	ERCSO15100006	ERCBC15500010	ERCBI15304001
ERCCO16004005	ERCSO15100007	ERCBC15500010	ERCBI15304001
ERCCO160041202	ERCSO15100005	ERCBC15500009	ERCBI153041201
ERCCO160041204	ERCSO15100006	ERCBC15500010	ERCBI153041201
ERCCO160041205	ERCSO15100007	ERCBC15500010	ERCBI153041201
ERCCO160044401	ERCSO15100006	ERCBC15500011	ERCBI153044401
ERCCO160044402	ERCSO15100007	ERCBC15500011	ERCBI153044401
ERCCO16004501	ERCSO15100006	ERCBC15500011	ERCBI15304501
ERCCO16004502	ERCSO15100007	ERCBC15500011	ERCBI15304501
ERCCO160047601	ERCSO15100006	ERCBC15500011	ERCBI153047601
ERCCO160047602	ERCSO15100007	ERCBC15500011	ERCBI153047601
ERCCO16005001	ERCSO15100007	ERCBC15500013	ERCBI15305001
ERCCO16005002	ERCSO15100008	ERCBC15500014	ERCBI15305001
ERCCO16005003	ERCSO15100008	ERCBC15500014A	ERCBI15305001
ERCCO160050801	ERCSO15100007	ERCBC15500013	ERCBI153050801
ERCCO160050802	ERCSO15100008	ERCBC15500014	ERCBI153050801

Ce document n'est pas contractuel - This document is not contractual



## ERCEM GV SEAL SPARE PARTS



REFERENCE ERCEM INJECTION	SOUFFLET	BAGUE CARBONE	Bague INOX
ERCCO160050801	ERCSO15100007	ERCBC15500013	ERCBI153050801
ERCCO160050802	ERCSO15100008	ERCBC15500014	ERCBI153050801
ERCCO160050803	ERCSO15100008	ERCBC15500014A	ERCBI153050801
ERCCO16005501	ERCSO15100007	ERCBC15500013A	ERCBI15305501
ERCCO16005502	ERCSO15100008	ERCBC15500014B	ERCBI15305501
ERCCO16005503	ERCSO15100008	ERCBC15500014C	ERCBI15305501
ERCCO16005504	ERCSO15100009	ERCBC15500016	ERCBI15305501
ERCCO160057101	ERCSO15100007	ERCBC15500013A	ERCBI153057102
ERCCO160057102	ERCSO15100008	ERCBC15500014B	ERCBI153057102
ERCCO160057103	ERCSO15100008	ERCBC15500014C	ERCBI153057102
ERCCO160057104	ERCSO15100009	ERCBC15500016	ERCBI153057102
ERCCO16006001	ERCSO15100008	ERCBC15500015	ERCBI15306001
ERCCO16006002	ERCSO15100008	ERCBC15500015A	ERCBI15306001
ERCCO16006003	ERCSO15100009	ERCBC15500016	ERCBI15306001
ERCCO160063501	ERCSO15100008	ERCBC15500015	ERCBI153063501
ERCCO160063502	ERCSO15100008	ERCBC15500015A	ERCBI153063501
ERCCO160063503	ERCSO15100009	ERCBC15500016	ERCBI153063501
ERCCO16006501	ERCSO15100008	ERCBC15500015B	ERCBI15306501
ERCCO16006502	ERCSO15100008	ERCBC15500015C	ERCBI15306501
ERCCO16006503	ERCSO15100009	ERCBC15500016A	ERCBI15306501

### ERCEM GV SHAFT <50MM

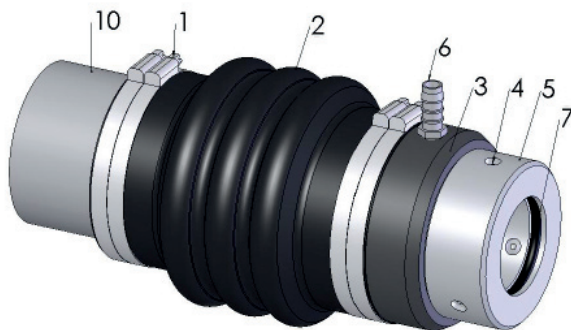

### ERCEM GV SHAFT >50MM

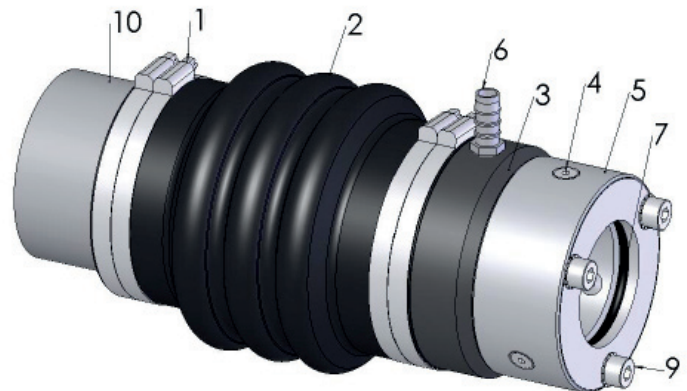

### OPERATING PRINCIPLE

ERCEM GV shaft seal is a technology derived from submarine seals adapted to marine shafts.

ERCEM GV is composed of an elastomer reinforced Kevlar bellow (2) which is mounted on the sterntube (10) with 2 hose clamps (1). A graphite ring (3) provided with a water inlet (6) is mounted on the other side of the bellow with two hose clamps. The stainless steel ring (5), fastened to the shaft by 3 grub screws (4) compress the graphite ring thereby sealing between these two parts. Sealing between the stainless steel ring (5) and the propeller shaft is formed by two O-rings (7).



## PRECAUTIONS

- ➔ Mounting of the ERCHEM GV and any maintenance interventions must be carried out with the boat out of the water.
- ➔ During unpacking and installing the seal, take care not to damage the stainless steel ring and the graphite ring, the contact faces sealing must be clean and scratch free.
- ➔ Check for missing parts before installing the seal (see parts list above).
- ➔ Never disassemble the water inlet on the graphite ring and never try to tighten it.

## ASSEMBLING INSTRUCTION

- 1** Remove coupling from shaft and back off the propeller shaft to exit the old seal.
- 2** Clean carefully the propeller shaft with fine sand paper (600 grit) so that it is no longer any rough edges that could damage the O-rings in the stainless steel ring during assembly. Be especially attentive to keyways who need to be carefully deburred.
- 3** Slide bellow (2) with graphite ring (5) and the clamps (1) over the shaft to the sterntube (10), graphite ring (3) on engine side.
- 4** Slide bellow (2) on the sterntube (10) along the length of the sleeve. The length of the bellow mounted on the tube must be sufficient so that the two clamps (1) provide a clamping on the tube (10).
- 5** Visually align the bellows (2) and graphite ring (3) with the propeller shaft, the graphite ring (3) must not be in contact on the shaft.
- 6** Tighten the two clamps (1) sterntube (10) side on the cuff of the bellow (2) (tightening torque 10 Nm).
- 7** Place the stainless steel ring (5) gently on the propeller shaft with the O-rings (7) mounted, polished face on the graphite ring side. To facilitate installation, use soapy water. Do not lubricate the shaft with oil or grease.
- 8** Bring the stainless steel ring (5) in contact with the graphite ring (3) without applying a compression on the bellow. Mark this position on the shaft with a marker just in front of the stainless steel ring to identify the neutral position (no compression).
- 9** Slide the stainless steel ring aft on the shaft to obtain the compression dimension C shown in the table attached in relation to the mark made earlier on the propeller shaft, in correspondence with your ERCHEM model.
- 10** Hold the stainless steel ring with this compression and tightened, using the Allen key supplied, the 3 screws (4) alternatively without applying the tightening torque on a single screw. The tightening of the 3 screws must be alternately and gradually to the required torque (see table below). The 3 screws need to be secured with a low brake fluid thread Loctite type or Omnifit.
- 11** ERCHEM seals for propeller shaft greater than 50 mm in diameter has a lid to facilitate mounting. For these models the cover and the O-rings must be removed before the assembly of the stainless steel ring on the shaft. Once the stainless steel ring compression stuck to his score, mount the O-rings and the cover. Fasten with the 3 screws CHC (9) and lock washers to the requested torque (see table below).



## 12 ERCEM GV must be supplied with water, so:

- Use a plastic or reinforced rubber hose complying with the safety rules, flexible enough not to seek the graphite ring. We offer kits with connections to suit your application.
- Insert the hose and the clamps on the water inlet fitting of the graphite ring.
- Do not over tighten the hose clamps on the plastic inlet.
- Connect the hose to the engine cooling circuit to the return of sea water prior to injection into the exhaust, or on a strainer.
- The hose will be supported by a bracket above the seal so as not to weigh on the graphite ring.

### Venting:

- Install an hose bypass with the open air allows for beaching vessels the complete filling of the sterntube when handing in water and for fast boats, prevents depression phenomena which can take off the graphite ring.
- The end of the air inlet hose should be at least 70 cm above the water line and need to be around the center of the boat.

13 Do not make up the flexible loop so as not to cause siphoning.

14 When launching the boat, make sure the air vacuum in the bellow compressing it until the appearance of water. Make sure the water in the bellows is continuous, ErceM seal must always be supplied with water.

15 Check that the water flow is sufficient to lubricate the graphite ring but that the bellows does not rise too much pressure (maximum permissible pressure: 0.7 bar).

---

## MAINTENANCE

At every launching of the boat including after beaching:

- Check the cleanliness of the contacting surfaces of graphite and stainless steel rings
- Ensure the empty air in the bellows compressing it until the appearance of water
- Check the bellow compression

Every years:

- Check the good condition of the bellow
- Replacement of the bellows is recommended from 3 years for simple bellows, 5 years for reinforced bellows
- Check the wear of the graphite ring
- The wear of graphite rings vary depending on applications, configurations and operating conditions. In all cases, the graphite ring must be changed:
  - If large water jets are detected
  - When the wear of the latter exceeds 4mm in thickness
  - In case of damage



## TROUBLESHOOTING

### Premature wear of the graphite ring with strong projections:

- Check the compression of the bellow and adjust if necessary
- Check the surface condition of the contact surfaces of graphite and stainless steel rings, clean the stainless steel ring with a clean cloth or replace parts as necessary.
- Check and control the flow rate and the water supply pressure in the graphite ring. The maximum pressure allowed by the ERCHEM seals is 0.7 bar.

### Leak at rest:

- Check the surface condition of the contact surfaces of graphite and stainless steel rings, clean the stainless steel ring with a clean cloth or replace parts as necessary.

### The bellow and graphite ring oscillate in operation:

- Check the stainless steel ring is properly perpendicular to the propeller shaft using a square and correct the position if necessary.
- Check the graphite ring does not touch the propeller shaft and that it is not warped.
- Make sure the graphite ring is not driven by a movement of the hose.

## TORQUES

Item	Shaft Ø	Designation	Torque
4	22 to 25.4mm	<b>STHC Screws M6x10</b>	5 N.m
4	28 to 41.2mm	<b>STHC Screws M8x15</b>	11 N.m
4	44.45 to 50.8mm	<b>STHC Screws M10x15</b>	22 N.m
4	55 to 63.5 mm	<b>STHC Screws M12x20</b>	38 N.m
9	55 to 63.5mm	<b>CHC Screws M8x16</b>	11 N.m
1	All	<b>Stainless Steel A4 Clamps</b>	10 N.m
NR	All	<b>Water pick up kit clamps</b>	5 N.m

## IMPORTANT

**After mounting the ERCHEM, do not forget to rub the water inside the bellows up slightly compressing it until visual appearance. Make sure the water in the bellows is continuous, ERCHEM seal must always be supplied with water.**

## WARRANTY

ERCHEM seals are guaranteed for a period of 1 year against defects or hidden defects or missings after shipping. The warranty applies only to the only replacement of the offending goods or missing after the joint inspection, with no compensation whatsoever and provided a claim is made within 10 days after receipt of the goods.

Taking guarantee can be requested when the seals have been modified, improperly installed / maintained or are not appropriate to the application.

For more information, see our terms of sale.