

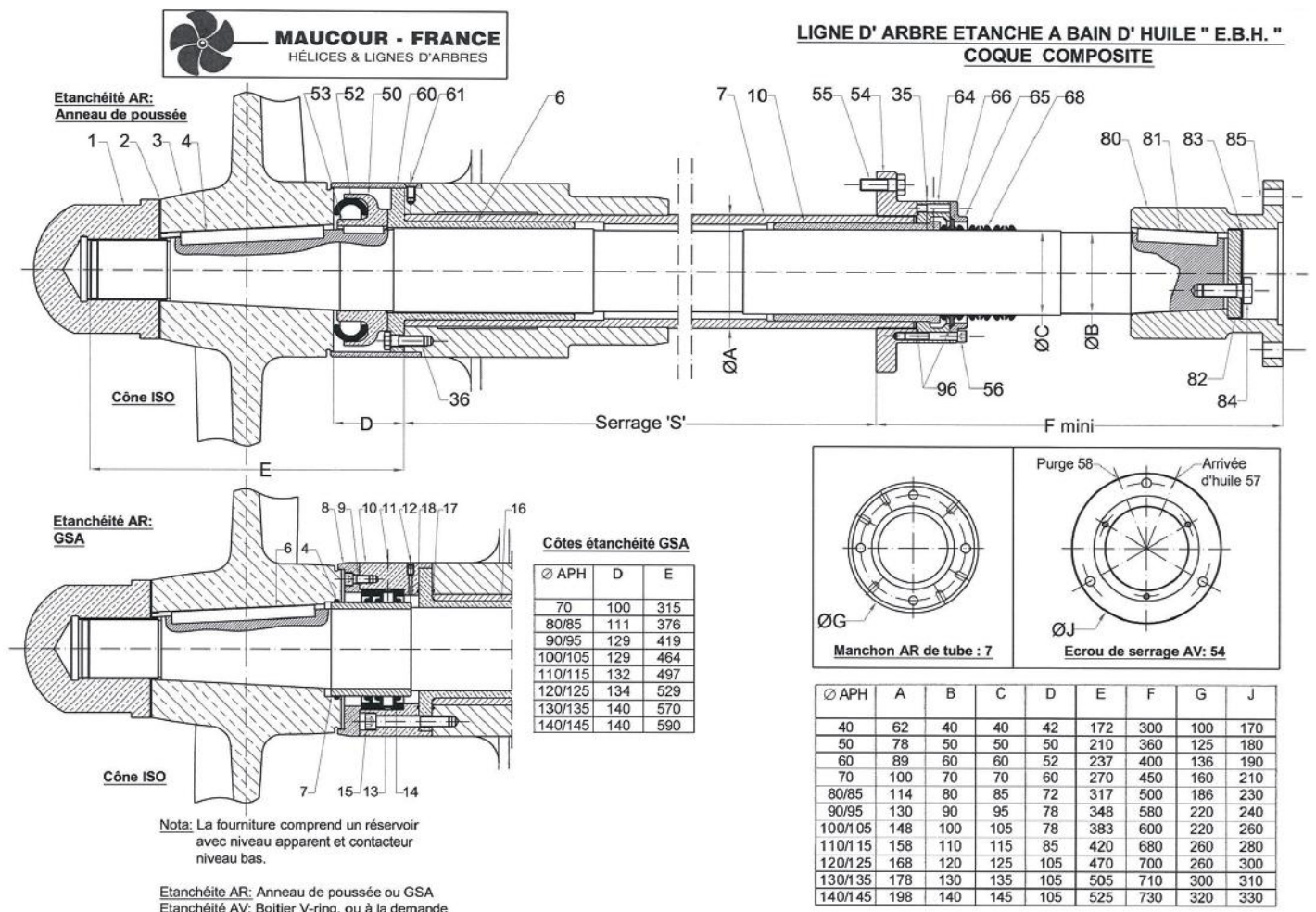

Oil lubricated shaft lines are used to equip professional boats, irrespective of the material of the shell. We offer a standard version with a front seal type V-ring and a rear seal with rotating seal / thrust ring or GSA housing.

GRP HULL



Ce document n'est pas contractuel - This document is not contractual



Please contact us for more technical information if you have a project