





Customer: ..... Email: .....  
 Phone: ..... Adresse: .....  
 .....

**VESSEL**

Vessel Name: ..... Builder: ..... Model: .....  
 Monohull  Multi-hulls

**HULL TYPES**

  
 Sailing

  
 Displacement

  
 Semi-planing

  
 Planning

Waterline length (in m): ..... Waterline width (in m): .....

**HULL MATERIAL**

Wood  Fiberglass  Steel  Aluminium

**DISPLACEMENT**

Loaded (tons): ..... Max speed provided: ..... knots

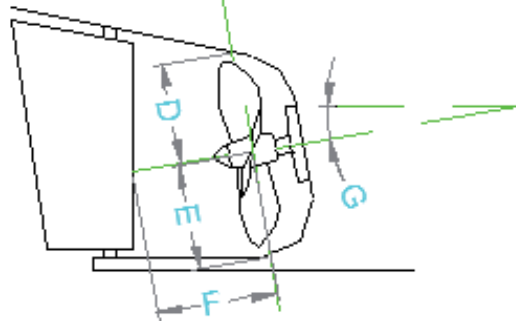
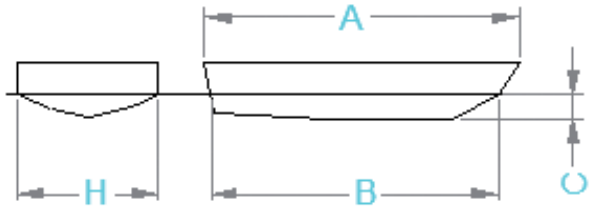
A (m): ..... B (m): ..... C (m): ..... D (mm): .....  
 E (mm): ..... F (m): ..... G (°): ..... H (m): .....

**COMMENTS:** .....

.....

.....

.....

.....

.....

Ce document n'est pas contractuel - This document is not contractual



**PRESENT PROPELLER DETAILS**

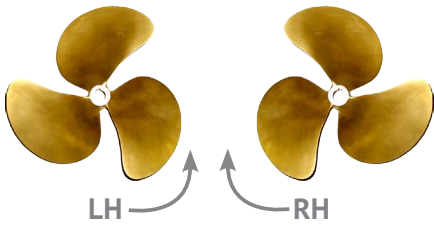

Diameter & Pitch (D x P) : .....  
 Number of blades: .....  
 Brand: .....  
 DAR: .....

Direction of rotation as viewed from behind vessel looking forward

1 Prop  Rotation: .....  
 2 Props  Rotation: .....Port .....Stbd

**PRESENT SHAFT DETAILS**

d1 (mm): ..... W (mm): .....  
 d2 (mm): ..... h (mm): .....  
 L (mm): ..... t (mm): .....

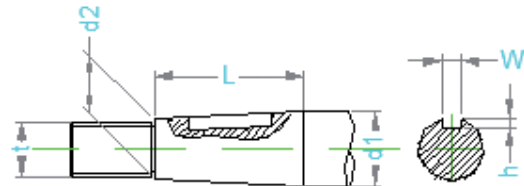

**BOSS PROPELLER DETAILS**

d3 (mm): ..... W3 (mm): .....  
 d4 (mm): ..... h3 (mm): .....  
 L1 (mm): ..... D (mm): .....

Key  
 // with taper  
 // with the axis

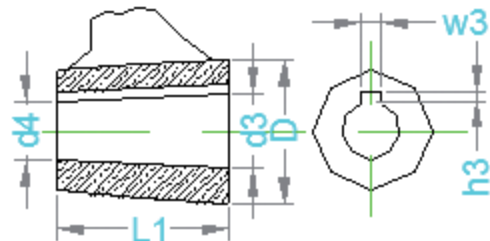

**ENGINE / GEARBOX**

Manufacturer: ..... Model: ..... Year: .....  
 Number of engines: ..... Max. Power(HP / KW): ..... Max. RPM: .....  
 Gearbox Manufacturer: ..... Type: ..... Gearbox ratio : ...../1

**RESERVED TO THE OWNER OR AGENT**

Mrs, Mr ..... declares the informations attached are contractual.  
 Read and approved,  
 The ..... Signature: